

Saw Guides for ordinary Table Band Saws

with guiding elements made of the original CHACO Low Friction Material



MT 30 V+V

The ultra-compact guide for the hobby and the professional, for saw-blades 4 to 35 mm (0.15 to 1.4") wide. With two rows of guiding elements for maximum blade stability. This guide is also suitable for saws with tilting table.

Dimensions:

W = 110 mm (4.3 in.)
H = 95 mm (3.7 in.)
D = 75 mm (3.0 in.)



M 35 V+V

Tens of thousands satisfied customers around the world are proof of the quality advantages of this all purpose saw guide for blades (6) 12 to 40 mm (0.5 to 1.5") wide. Designed in double V form for best view at work-piece. Upper guide with protection shield.

Dimensions:

W = 165 mm (6.5 in.)
H = 180 mm (7.1 in.)
D = 85 mm (3.4 in.)



M 100 H+H

A precision guide of compact design for heavy duty usage. Suitable for saw-blades 40 to 100 mm (1.5 to 4") wide. Upper and lower guide identical and designed for easy and quick change to suit l.h. and r.h. machines.

Dimensions:

W = 90 mm (3.5 in.)
H = 114 mm (4.5 in.)
D = 170 mm (6.7 in.)



M 35 V+H

Specifications like guide M35 V+V. Upper guide M35 V/o in V-shape for easy access and open view at work piece. Lower guide M 35 H/u of compact design for machines with limited space below the table.

Dimensions (M 35 V/o):

W = 165 mm (6.5 in.)
H = 180 mm (7.1 in.)
D = 85 mm (3.4 in.)



M 35 H/u

Lower guide made of two parts for easy and quick change to suit l.h. and r.h. machines. Horizontal guiding elements are fast and easy to adjust.

Dimensions (M 35 H/u):

W = 140 mm (5.5 in.)
H = 150 mm (5.9 in.)
D = 70 mm (2.75 in.)

Advantages of CHACO Saw Guides:

- Guiding elements are made of the original CHACO Low Friction material that guide the blade firmly over the whole width, thus giving maximum control of the blade, as well as leaving it cool and clean.
- Compact design allows positioning of guides close to work piece, thus allowing faster cutting speeds and feed rates.
- Back stops with two ball bearings and hardened contact ring (exception: MT 30 V with single ball bearing)
- Extremely slow wear on guiding elements.

CHACO fixing parts for standard saw guides

BTO upper

(mounting bracket, flange and rod)



BTU lower

(flange and rod)



Content of delivery:

One complete saw guide consists off:

- 1 upper guide including standard fixing parts BTO
- 1 lower guide including standard fixing parts BTU
- 1 installation and operation manual

Tailor-made guiding elements and pressure guides for any band saw made of the CHACO Low Friction Material.

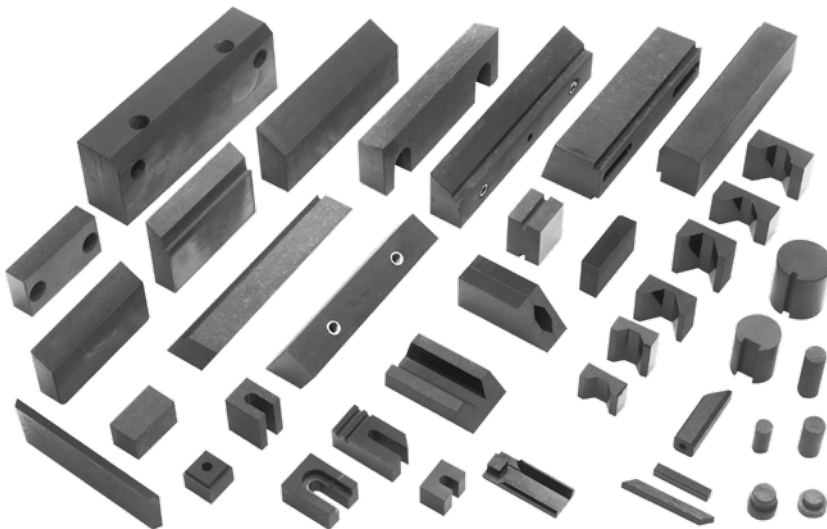

Manufacturers:

CHACO PRODUCTS LTD.
Stettbachstrasse 10
CH-8600 Dübendorf / Switzerland
Telephone +41 43 819 12 12
Telefax +41 43 819 12 15
E-Mail mail@chaco.ch
www.chaco.ch

Represented by: